

MANUFACTURING OF IŞIK KUTUSU, ONLY FOR USING NON COMMERCIAL (IN TURKISH)

For my darling, the [invention patent](#) has been donated to the humanity.

5 If use of the invention commercial or malicious; everyone has the right to sue the national or international courts.

The invention (Işık Kutusu) has been [tested successfully](#) with The plant materials of [The Virtual Herbarium of Lake Van Basin](#) since 2005 30.05.2008 **Enjoy !!! Savor the human being and humanity !**

Inventor [Prof. Dr. Nasip DEMİRKUŞ](#)

10

For More Information;

<http://www.vanherbaryum.yyu.edu.tr/kutu/index.htm>

<http://www.vanherbaryum.yyu.edu.tr/kutu/p/index.htm>

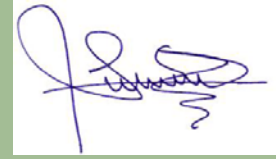

15

DESCRIPTION

A device for transferring pictures and images of motionless beings and objects to the computer, depending on the qualities of the scanner.

20

The invention was accomplished as a device that can transfer the pictures and the images of motionless beings and objects to the computer, depending on the qualities of the scanner.

25

For this purpose, a number of different search engines on the Internet have been the focus of our concern for the compatibility of such a device. But after a thorough investigation had been conducted through search engines like yahoo, MSN Home Hotmail, Alta-vista, Lycos, Excite and web sites like <http://www.turkpatent.gov.tr> by entering key words like scanner, scanning a body, scanning a material, scanning a matter, scanning a substance, scanning a thing etc. no device of such quality has yet been found; the case was also true for digital libraries and the other multimedia literature.

30

In terms of both its functions and mechanism, we haven't found the identical counterpart of the device. Devices, which show a close resemblance, are those that operate by laser or X rays in order to scan various parts of the body for radiological examination in the field of medicine, information about such devices can be found in such addresses of the web as <http://www.bodyscans.com/> and <http://www.cyberfx3d.com/>. But since such

35

technologies are considered to be expensive and harmful for the health there are drawbacks for their applicability, let alone the precision and the attention that should be required for the expertise. As for the device, which has been invented by us, it has got a liability to the scanners with flatbed, which work with fluorescent light; so it has got a quality that makes scanners more practical and productive together with the compatibility

of its cost. Minimum qualities of the scanner used in the trials made by this device are designed as thus:

- a. Scanner type; flatbed
- b. Scanning element; charge-coupled device (CDD)
- 5 c. Light source; single cool cathode fluorescent
- d. Hardware resolution; 1200 dpi hardware super sampling-600 dpi optic
- e. Selectable resolution; 12 dpi to 9600 dpi at 100 % scaling
- f. Scanning modes; 1 bit (black & white), 4 bit gray (16 gray levels), 8 bit (256 gray or colour levels), 36 bit (16.7 million colours)
- 10 g. Scaling; 1% to 400 % in increments at 600 dpi (depends on resolution)
- h. Image processing; dithering, thresholding, scaling, interpolation, sharpening, Gamma adjustment, matrix adjustment (These technical qualities were taken from HP ScanJet 6200C Scanner user guide).

15 Figure 1 shows the image of the device mentioned above from aside, afront and above in $\frac{1}{4}$ scaling.

Figure 2 shows the image of adjustment plaque numbered 04 from above, afront and aside in $\frac{1}{4}$ scaling.

Parts of the device which have got particular numbers and figures indicated in Figure 1 and Figure 2 have been designed to possess qualities as thus:

20 01 [Hoop box](#); it was made up of fiberboard; a transparent and isolated band has been attached to the edges which contact with the scanning glass of the hoop so that the glass couldn't be scratched. Inner parts of the hoop have been covered with pure white paper which does not reflect or absorb the light (in a way that the picture printing paper's surface comes out within the range of a 720 dpi in the device) and it has been covered with lake dye so that the scanner's light and the scanned object could not be affected by the light from outside.

30 02 [Adjustment ruler](#); it was made up of wood; its surface was numbered with unit frequencies and holes were drilled for the holding the adjustment pin (05) next to each number; the aim is to manage various adjustment highs to be functioned by the device for reflecting the light coming from the scanner to the object in the most practical and ideal way.

35 03 [Metallic attachment string](#); it was made up of the metal which is non-corrodible. This string was mounted to the tip of the right edge of the hoop box in a fixed way (01). The aim is to manage the attachment of one end of the rope holding the pin (06) and to let the adjustment pin (05) to be steadily seen above the hoop box.

04 [Adjustment plaque; it was made up of fiberboard](#); and the whole surface was covered with a pure white paper painted in pure white (lake) dye (in a way that the white surface of the picture printing paper comes out in a range of 720 dpi in the device. The

aim is to capture the light coming from the scanner correlated to the height of the adjustment ruler (02) and then prevent it from being scattered so that it could be in harmony with the dpi count that was preferred.

05 [Adjustment pin](#): it was made up of a metal that was non-corrodible and a transparent band was stuck to it in order to prevent the device from damaging and keep it clean. The aim is to pass the adjustment plaque (04) to the hole next to the number approximating this height in order to hang it in the height of the object.

06 [Rope for holding-up of the pin](#): it was made up of cotton; it should have a length up to the adjustment plaque; its function is to let the adjustment pin (05) to stay above the hoop box steadily.

Operating Principle of the Device

A- [The object to be scanned](#), after it had been cleaned, is put on the scanning glass (in a way that it couldn't cause any damage to the glass).

[The adjustment ruler \(02\) which is shown in Figure 1 is brought to the uppermost position and adjustment pin \(05\) is passed to the approximate hole and the adjustment plaque \(04\) is held in the uppermost position.](#)

B- [While the adjustment plaque \(04\) is in the uppermost position within the hoop box \(01\)](#), the device is being closed down, the object to be scanned, having been put in it.

C- [The pin for the adjustment ruler \(05\) is taken off from the unit and is slide downwards slowly; when it touches the objects it is stopped. In a way, this is the height of the object. In this high, the adjustment pin \(05\) is passed to the hole on the adjustment ruler \(02\).](#) In the case of the sensitive and smooth objects, the heights of such objects to be placed on the scanner are measured before hand. The adjustment pin within the range of such a high is passed to the hole on the adjustment ruler (02); as the adjustment plaque (04) is lifted higher than the object, the background image shifts its colour to white, gray and blue tones.

D- Within the course of our trials, a programme designed as HP Scan Jet 6200C Scanner and Adobe PhotoDelux Business Edition 1.0 for Windows was used and images and objects were scanned with an appropriate dpi. Pictures were scanned with 240 dpi; objects and spaces bigger than 1 cm with 245-270 dpi and objects and spaces smaller than 1 cm with 270- 9600 dpi. After such process had been carried out these entities were transferred to the computer. (The picture or the images of the objects having been adopted to such programme as Adobe PhotoDelux Business Edition 1.0, colour adjustment filtration of the visions was automatically processed by clicking such buttons as 'Advanced', 'Edit', 'Quality', 'Extensis IntelliFix' respectively in the programme).

After this process, the images were printed on papers of 360, 720 and 1440 dpi, using Epson Stylus Colour 740 printer.

In the end, we have taken remarkably good results in terms of reflecting those visions on the papers.

5 E- A file characterized as JPEG and PDD has been composed in order to record those images and visions that were obtained by our device. PDD file has yielded to good results for zooming and printing; as for the JPEG file, it has proved to be very useful for the presentation programmes and the Internet. In the course of our trials after a process of scanning in 270-9600 counts objects and spaces that were smaller
10 than 1 cm have been magnified through such programmes as Adobe PhotoDelux Business Edition 1.0 for Windows, PowerPoint, Microsoft Photo Editor, PhotoShop, Photo Plus 4, Corel PhotoPaint 9; practical and positive results on a highest level were taken in digital imaging and printing. In a scanning with 360 dpi, depending on the quality of the scanner, a five-times-magnitude of the printing was sharply achieved. In such images,
15 clarity can be achieved up to 9 times in every stage at 200% zooming. In a scanning with 720 dpi a clear printing of seven-times-magnitude was achieved. Clarity in this image can be achieved up to 18 times in every stage at 200% zooming. In a scanning with 1666 dpi and 100% zooming the image was magnified 21 times and clarity was achieved in every stage. Clarity in the highest zooming was achieved with 33% - 50% zooming in a
20 scanning of 9600 dpi scale. The magnifying rate in the percentage was 3991.68%-6048% (39.9168-60.48 times bigger than the real object.) clarity could be reached in every stage. This has given us the possibility of examining the minute details of objects as successful as the devices of such power (magnifying glasses-microscopes). In all of the programmes mentioned above (Adobe PhotoDelux Business Edition 1.0 for Windows, PowerPoint,
25 Microsoft Photo Editor, PhotoShop, Photo Plus 4, Corel Photo Paint 9) rulers with delicate adjustment were used and the dpi count, which was equal to the real object and its image, was determined as 79; from this point the approximate coefficient was calculated as $100/79=1.2658822785$. Depending on such count, an equality as the following was formulated:

30 B: % magnifying rate (magnitude of the real object in coefficient)

D: Dpi count (the resolution count obtained from scanner)

U: Adapting coefficient (~ 1.26)

Z: Zooming count (for converging)

$$B=D \times U \times Z \quad (B= D * U * Z)$$

35 Example question 1: What are the magnifying counts of an objects scanned with 1200 dpi and zoomed with a- 100% and b-50% rate?

Answer: a- $B= 1200 \times 100 / 100 \times 1.26 =$ that object will be magnified 1512% (15.12 times bigger than the real object).

b- $B=1200 \times 50/100 \times 1.26=$ that object will be magnified 756% (7.56 times bigger than real object).

Example question 2: How much dpi could be preferred for scanning in order to obtain a 4000% times of the magnitude of the object in a 33% zooming of the monitor?

5 Answer: $4000 = D \times 33/100 \times 1.26$; D can be counted as 9620 dpi here.

Within the context of such devices today in the field of technology scanners are used for scanning pictures and slides; generally, transferring of images of the objects to the computer is either made by digital and classical cameras in a direct way or made by slides and pictures. There occurs a loss of colour and detail in such images while being
10 transferred to the computer from the cameras, films, pictures or slides respectively; there is a loss of time, labour, quality and economy.

But this device, which was invented by us, has got a practical and simple use for such purposes and could be a prototype suitable for any technological enhancements. This invention can be used in such areas as medicine, criminology laboratories, the fauna
15 and flora museums of the universities, archaeology museums etc.

In such fields as textile industry in the analysing and pressing of textile samples like leathers or various other products by a zooming (magnifying) up to 60 times, the device could be used practicably; analysis and colourful press of various means and modes of such products could well be achieved. Our device has proved to be effective in
20 examining fingerprints and forensic evidences in the laboratories of criminology.

In addition to these uses, the device is considered to be very useful in the university museums especially in the field of biology, geology, mining etc in terms of transferring dry or fresh samples of plants and animals (placid ones), minerals, rocks etc to the digital environment for scientific purposes on a professional or non-professional
25 level. Since such samples, which are of great scientific prominence, are deteriorated in those museums as the time passes, it would be of great importance to transfer those entities to the digital environment; such transfer could well be managed by our device.

This product will also be practical for transferring originally precious works in the museums of Arts and Archaeology as well as in philately in order to be distinguished from
30 imitations for scientific, professional or amateurish purposes.

In the field of medicine, the device has proved to be beneficial in analysing morphological disorders in dermatological and pathological examinations as well as in detailing scientific images of experimental animals.

This device has facilitated to easier construction of digital museums, digital
35 libraries, and digital collections and provided good opportunity for transferring such entities to the cyberspace and thus, such a service has become easier for scientific, professional and non-professional purposes. A saving of time and cost can be made with such images which are closest to the real ones by the aid of this device; furthermore, it will give greater contribution to the efficiency and speed of scientific studies in such fields; it will, for example, be possible to transfer a houseplant or a rosebud to the computer for
coultral, educational, investigational or internet purposes in 2-4 minutes of time.

REQUIREMENTS

1. Our invention is a device made up of fiberboard and designed for transferring pictures, images of motionless beings and object to the computer depending on the quality of the scanner; a hoop box (01) which was isolated with a transparent band was devised in order to avoid possible damages caused by fiberboard to edges of the scanning glass. The device has also been constituted of such integrities as an adjustment ruler (02), metallic attachment string (03) made of a non-corrodible material, an adjustment plate (04) made of fiberboard painted in white and covered with pure white paper, which does not show any brightness or peculiarity to absorb and reflect the light, an adjustment pin (05) made up of stainless metal and isolated with a transparent band and a rope (06) made of cotton for holding and attaching of the pin.
2. The hoop box mentioned in the Requirement 1 and designed in the figure of 01 has got a peculiarity for entirely preventing the scanning light and the scanned object from being effected by the light of the outside environment; the inner surface of this box shows a speciality not to reflect or absorb the light on an undesirable level.
3. The adjustment ruler mentioned in the Requirement 1 and designed in the figure of 02 has got particularity to reflect the light coming from the scanner to the object in an ideal way and is numbered with unit frequencies for providing various adjustment highs; holes for attaching the adjustment pin (05) to them are made in front of each number.
4. The metallic attachment mentioned in the Requirement 1 and designed in the figure of 03 is devised for binding one end of the rope (06) and was mounted to the top edges of the box on the right in order to steadily let the pin (05) to be on the box.
5. The adjustment plate mentioned in the Requirement 1 and designed in the figure of 04 has got a peculiarity to capture the light coming from the scanner in a way to be correlated with the height of the ruler, and to provide an appropriate scattering of the light adopted to the value of the dpi preferred.
6. The adjustment pin mentioned in the Requirement 1 and designed in the figure of 05 has got a peculiarity to let the adjustment plate (04) to stand in the height of the object by passing to the coinciding hole of the ruler in such a height and than to hang the adjustment plate (04).
7. The rope for pin attachment mentioned in the Requirement 1 and designed in the figure of 06 has got a peculiarity to let the pin to stay on the hoop box steadily. It has also got an aspect to be at least in the length extending up to the ruler.
8. The device mentioned in the requirement 1 is a prototype together with the using of scanners and has got a function to provide the following equality of a magnifying (zooming) even in the objects which are scanned with the highest dpi mathematically:

$$B = D \times U \times Z \quad (B = D * U * Z)$$

B: % the degree of the zooming (The coefficient of the zooming of the real object)

D: Dpi count (The rate of resolution scanned from the scanner)

U: Adapting coefficient (~ 1.26)

Z: Zooming count (convergence)

5

DATE SIGNATURE

30.05.2008

Prof. Dr. Nasip DEMİRKUŞ

10

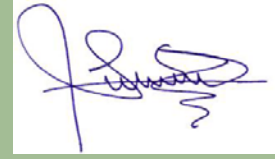

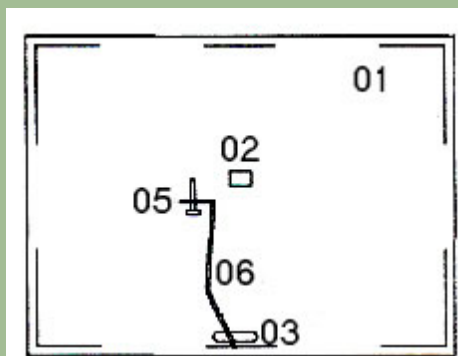
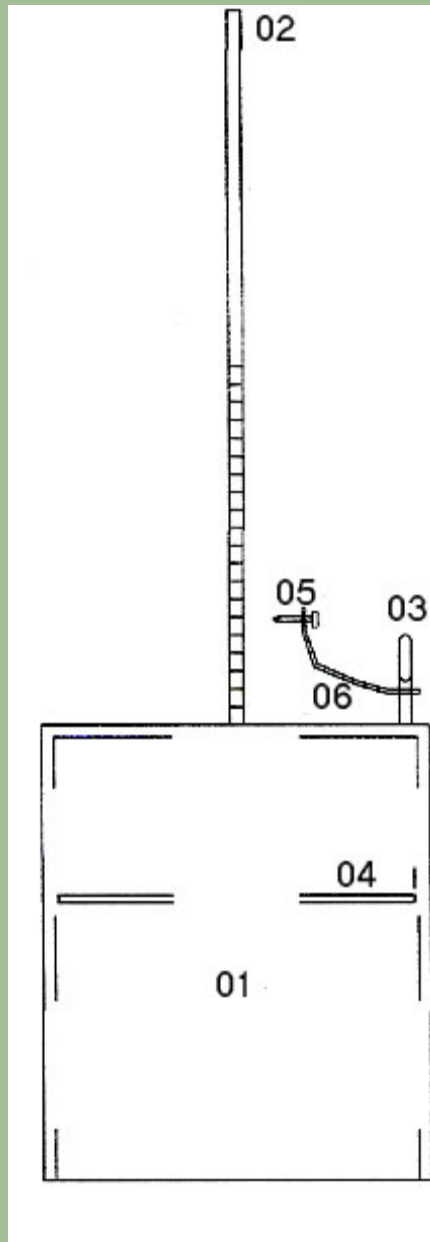

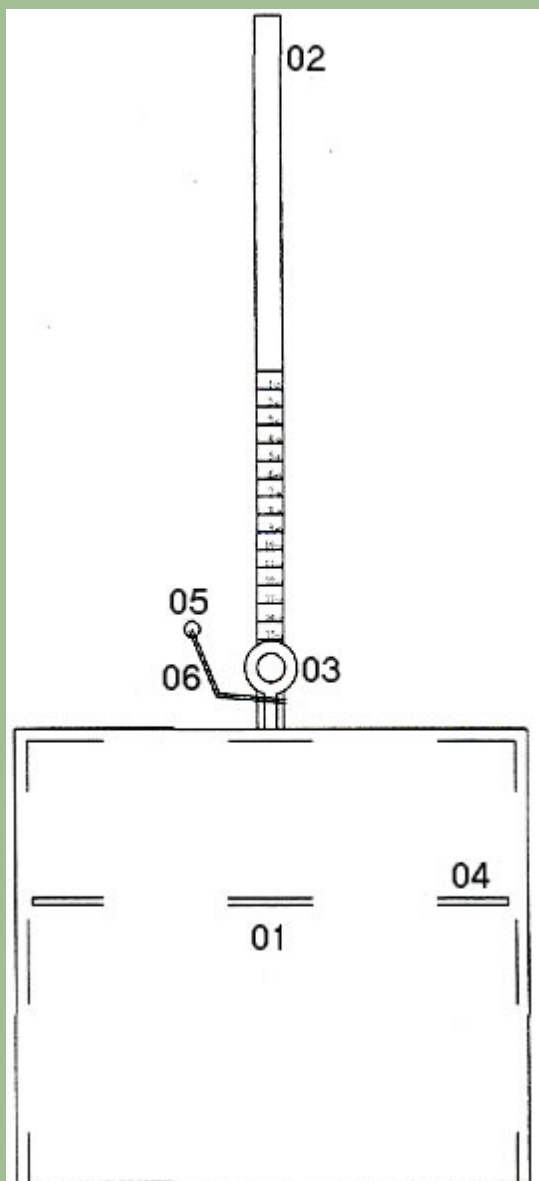
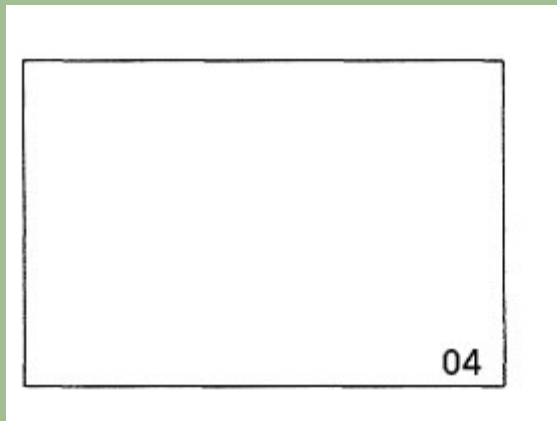

ABSTRACT OF DESCRIPTION

A device for transferring pictures, images of motionless beings and objects to the computer, depending on the quality of the scanner.

This device (Figure 1, Figure 2) provides remarkably good results in transferring three-dimensional images of motionless beings and objects to the computer with a qualitated imaging and printing when used with scanners. The quality of the images during the stages of photo cameras, films, picture printing yields to the saving of time and economy. Our device also provides facility for the analysis of the images of various entities in a number of fields in digital environment with a magnitude up to 60 times bigger than the real object (6000 %). It is very cheap and practical in the manifold uses of the scanners. An equality has been formulated in order to give the approximate count of the real magnitude depending on the dpi and the zooming counts.